



SWITCH YOUR KITCHEN
UPSIDE DOWN

PMF

 elica
aria nuova

WALL





L'ESSENZA

DESIGN FABRIZIO CRISÀ



BACK
ASPIRATION



SMART
INSTALLATION



CM 45



CM 50



ENERGY
CLASS
B

TEHNIČNI PODATKI TECHNICAL FEATURES

Velikost Size	60 - 90 cm
Izvedba Version	Odzračevalna Duct-out
Videz Finish	Črno steklo, Belo steklo Black glass, White glass

OSVETLITEV LIGHTING

Tipi Type	LED 2 x 2,5 W
Intenzivna moč Intensity	145 LUX
Temperature Temperature	3500 K

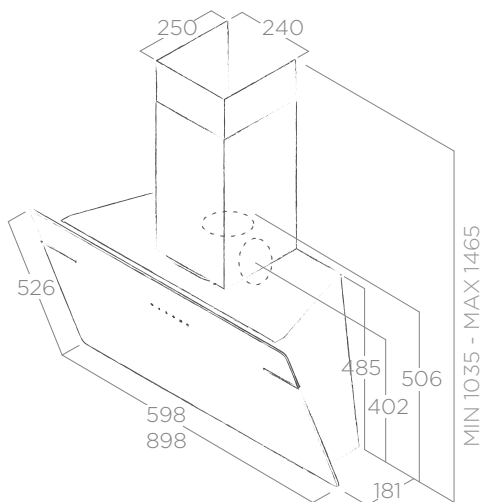

OBLIKA PERFORMANCE

Upravljanje Controls	3 Hitrosti + B na dotik 3S+B Touch Control
Pretok zraka Booster airflow	690 m ³ /h
Raven hrupa Noise level	65 db(A)
Popolna absorpcija Total absorption	255 W
Izhod Duct size	150 mm
Razred energetske učinkovitosti Energy class	B (A++/E)
Z aluminijastim mazalnim filtrom Grease aluminium Filter included	

DODATKI ACCESSORIES

Ogleni filter Charcoal Filter	CFC0140343
-------------------------------	------------

MODELI MODELS

L'ESSENZA BL/A/60	PRF0117403A
L'ESSENZA BL/A/90	PRF0117374A
L'ESSENZA WH/A/60	PRF0124233A
L'ESSENZA WH/A/90	PRF0124234A



STRIPE URBAN

ELICA DESIGN CENTER



BACK
ASPIRATION



SMART
INSTALLATION



CM 45



CM 65



ENERGY
CLASS
B

TEHNIČNI PODATKI TECHNICAL FEATURES

Velikost Size	90 cm
Izvedba Version	Odzračevalna Duct-out
Videz Finish	Železni izgled, Pocinkan izgled Cast iron effect, Zinc coating effect

OSVETLITEV LIGHTING

Tipi Type	LED 2 x 2,5 W
Intenzivna moč Intensity	203 LUX
Temperature Temperature	3500 K

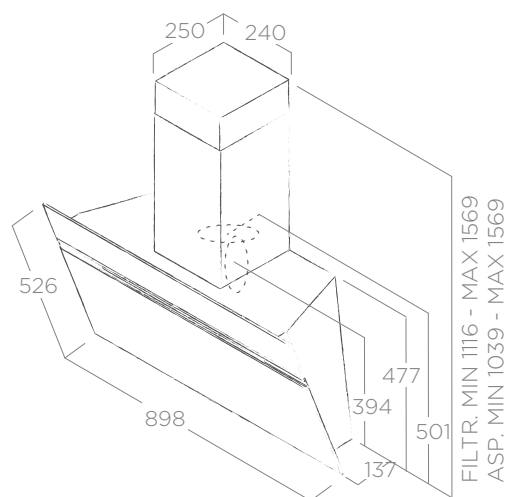

OBLIKA PERFORMANCE

Upravljanje Controls	3 Hitrosti + B na dotik 3S+B Touch Control
Pretok zraka Booster airflow	755 m ³ /h
Raven hrupa Noise level	65 db(A)
Popolna absorpcija Total absorption	265 W
Izhod Duct size	150 mm
Razred energetske učinkovitosti Energy class	B (A++/E)
Z aluminijastim mazalnim filtrom Grease aluminium filter included	

DODATKI ACCESSORIES

Ogleni filter Charcoal Filter	CFC0140343
-------------------------------	------------

MODELI MODELS

STRIPE URBAN CAST IRON/A/90	PRF0147738
STRIPE URBAN ZINC/A/90	PRF0147739



STRIPE LUX

ELICA DESIGN CENTER



BACK
ASPIRATION



SMART
INSTALLATION



CM 45



CM 65



ENERGY
CLASS
B

TEHNIČNI PODATKI TECHNICAL FEATURES

Velikost Size	60 - 90 cm
Izvedba Version	Odzračevalna Duct-out
Videz Finish	Črno steklo, Belo steklo, Nerjavno jeklo Black glass, White glass, Stainless steel

OSVETLITEV LIGHTING

Tipi Type	LED 2 x 2,5 W
Intenzivna moč Intensity	203 LUX
Temperature Temperature	3500 K

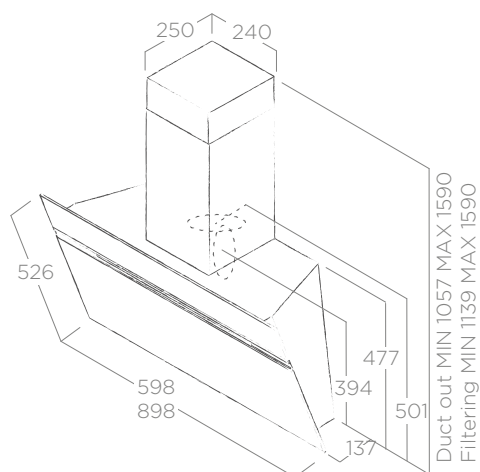

OBLIKA PERFORMANCE

Upravljanje Controls	3 Hitrosti + B na dotik 3S+B Touch Control
Pretok zraka Booster airflow	757 m ³ /h
Raven hrupa Noise level	65 db(A)
Popolna absorpcija Total absorption	265 W
Izhod Duct size	150 mm
Razred energetske učinkovitosti Energy class	B (A ⁺⁺ /E)

Z aluminijastim mazalnim filtrom Grease aluminium filter included

DODATKI ACCESSORIES

Ogleni filter Charcoal Filter	CFC0140343
-------------------------------	------------

MODELI MODELS

STRIPE BL/A/60/LX	PRF0100990B
STRIPE BL/A/90/LX	PRF0100991B
STRIPE IX/A/60/LX	PRF0100992B
STRIPE IX/A/90/LX	PRF0100993B
STRIPE WH/A/60/LX	PRF0100994B
STRIPE WH/A/90/LX	PRF0100995B



SHIRE

DESIGN FABRIZIO CRISÀ



TEHNIČNI PODATKI TECHNICAL FEATURES

Velikost Size	60 - 90 cm
Izvedba Version	Odzračevalna Duct-out
Videz Finish	Črno steklo, Belo steklo Black glass, White glass

OSVETLITEV LIGHTING

Tipi Type	LED 2 x 1 W
Intenzivna moč Intensity	58 LUX
Temperature Temperature	4000 K

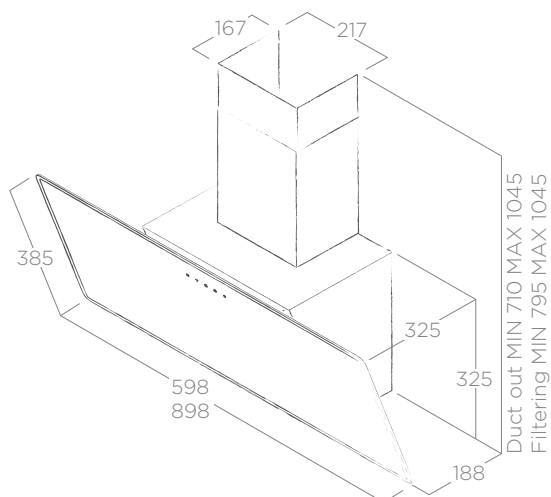

OBLIKA PERFORMANCE

Upravljanje Controls	2 Hitrosti + B na dotik 2S+B Touch Control
Pretok zraka Booster airflow	710 m ³ /h
Raven hrupa Noise level	60 db(A)
Popolna absorpcija Total absorption	272 W
Izhod Duct size	150 mm
Razred energetske učinkovitosti Energy class	B (A++/E)
Z aluminijastim mazalnim filtrom Grease aluminium filter included	

DODATKI ACCESSORIES

Ogleni filter Charcoal Filter	CFC0140343
-------------------------------	------------

MODELI MODELS

SHIRE BL/A/60	PRF0119819
SHIRE BL/A/90	PRF0119829
SHIRE WH/A/60	PRF0119823
SHIRE WH/A/90	PRF0119828



BELT LUX

DESIGN FABRIZIO CRISÀ



BACK
ASPIRATION



SMART
INSTALLATION



CM 45



CM 65



ENERGY
CLASS

TEHNIČNI PODATKI TECHNICAL FEATURES

Velikost Size	55 - 80 cm
Izvedba Version	Odzračevalna Duct-out
Videz Finish	Črno steklo, Belo steklo Black glass, White glass

OSVETLITEV LIGHTING

Tipi Type	LED 2 x 2,5 W
Intenzivna moč Intensity	381 LUX
Temperature Temperature	3500 K

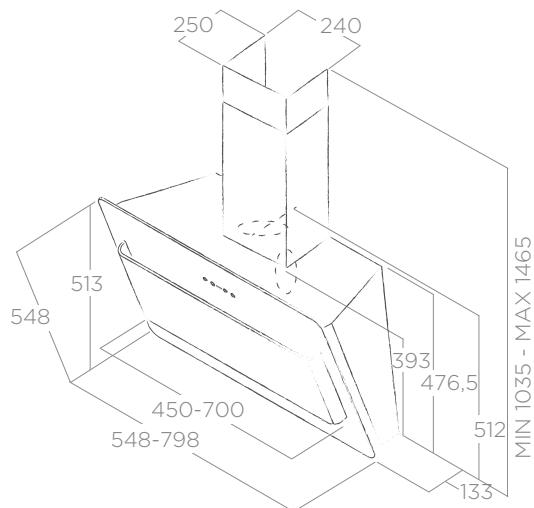

OBLIKA PERFORMANCE

Upravljanje Controls	3 Hitrosti + B na dotik 3S+B Touch Control
Pretok zraka Booster airflow	691 m ³ /h
Raven hrupa Noise level	68 db(A)
Popolna absorpcija Total absorption	265 W
Izhod Duct size	150 mm
Razred energetske učinkovitosti Energy class	C (A ⁺⁺ /E)
Z aluminijastim mazalnim filtrom Grease aluminium filter included	

DODATKI ACCESSORIES

Ogleni filter Charcoal Filter	CFC0140343
-------------------------------	------------

MODELI MODELS

BELT LUX BL/A/55	PRF0102284A
BELT LUX BL/A/80	PRF0102285A
BELT LUX WH/A/55	PRF0102286A
BELT LUX WH/A/80	PRF0102287A





SMART
INSTALLATION



LONG LIFE
FILTER



CM 50



CM 65



ENERGY
CLASS
B

TEHNIČNI PODATKI TECHNICAL FEATURES

Velikost Size	60 - 90 cm
Izvedba Version	Odzračevalna Duct-out
Videz Finish	Črna vtisnjena Embossed black

OSVETLITEV LIGHTING

Tipi Type	LED 2 x 2,5 W
Intenzivna moč Intensity	145 LUX
Temperature Temperature	4000 K

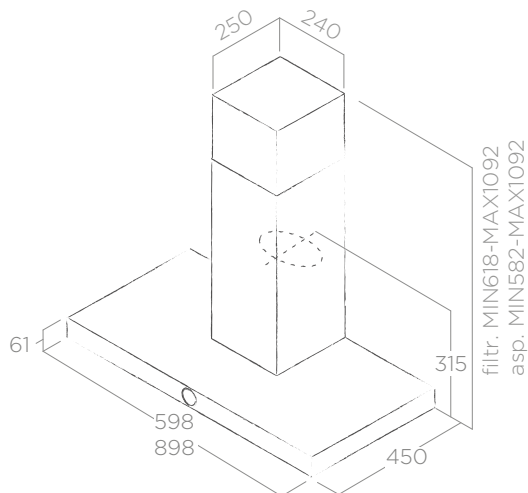

OBLIKA PERFORMANCE

Upravljanje Controls	Rotativo Elettronico 3V+I 3S+B Electronic Rotative
Pretok zraka Booster airflow	665 m ³ /h
Raven hrupa Noise level	65 db(A)
Popolna absorpcija Total absorption	260 W
Izhod Duct size	150 mm
Razred energetske učinkovitosti Energy class	B (A++/E)
Z aluminijastim mazalnim filtrom Grease aluminium Filter included	

DODATKI ACCESSORIES

Ogleni filter Charcoal filter	CFC0141529
Filter s podaljšanim delovanjem Long life filter	CFC0141725

MODELI MODELS

LOL BL/A/60	PRF0097782
LOL BL/A/90	PRF0097906



SPOT NG URBAN

ELICA DESIGN CENTER



TEHNIČNI PODATKI TECHNICAL FEATURES

Velikost Size	90 cm
Izvedba Version	Odzračevalna Duct-out
Videz Finish	Železni izgled, Pocinkan izgled Cast iron effect, Zinc coating effect

OSVETLITEV LIGHTING

Tipi Type	LED 2 x 2,5 W
Intenzivna moč Intensity	140 LUX
Temperature Temperature	3500 K

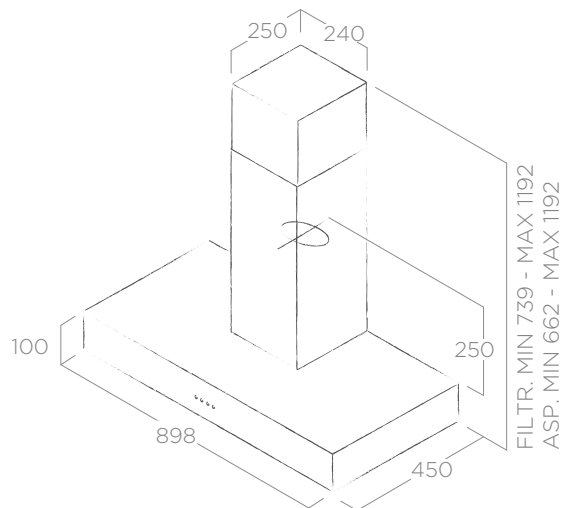

OBLIKA PERFORMANCE

Upravljanje Controls	3 Hitrosti meh. Gumbi 3S Mechanical Push Button
Maksimalni pretok zraka Max airflow	600 m ³ /h
Raven hrupa Noise level	69 db(A)
Popolna absorpcija Total absorption	255 W
Izhod Duct size	150 mm
Razred energetske učinkovitosti Energy class	B (A++/E)
Z aluminijastim mazalnim filtrom Grease aluminium Filter included	

DODATKI ACCESSORIES

Ogleni filter Charcoal filter	CFC0141529
Filter s podaljšanim delovanjem Long life filter	CFC0141725

MODELI MODELS

SPOT URBAN CAST IRON/A/90	PRF0147736
SPOT URBAN ZINC/A/90	PRF0147737



Železni izgled
Cast iron effect



Pocinkan izgled
Zinc coating effect



SPOT NG

ELICA DESIGN CENTER



TEHNIČNI PODATKI TECHNICAL FEATURES

Velikost Size	60 - 90 cm
Izvedba Version	Odzračevalna Duct out
Videz Finish	Nerjavno jeklo Stainless steel

OSVETLITEV LIGHTING

Tipi Type	LED 2 x 2,5 W
Intenzivna moč Intensity	141 LUX
Temperature Temperature	3500 K

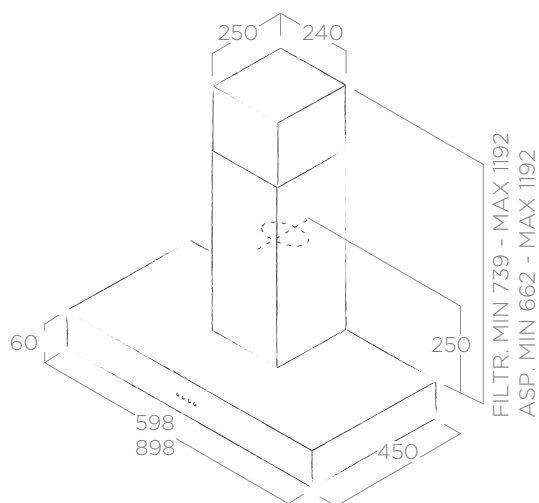

OBLIKA PERFORMANCE

Upravljanje Controls	3 Hitrosti meh. Gumbi 3s Mechanical Push Button
Maksimalni pretok zraka Max airflow	365 m ³ /h
Raven hrupa Noise level	62 db(A)
Popolna absorpcija Total absorption	140 W
Izhod Duct size	150 mm
Razred energetske učinkovitosti Energy class	D (A ⁺⁺ /E)

Z aluminijastim mazalnim filtrom Grease aluminium Filter included

DODATKI ACCESSORIES

Ogleni filter Charcoal Filter	CFC0141529
Filter s podaljšanim delovanjem Long Life Filter	CFC0141725

MODELI MODELS

SPOT NG H6 IX/A/60	55916388A
SPOT NG H6 IX/A/90	55916389A



LONG LIFE
FILTER

CM 50



CM 65

ENERGY
CLASS
B

TEHNIČNI PODATKI TECHNICAL FEATURES

Velikost Size	60 - 90 cm
Izvedba Version	Odzračevalna Duct out
Videz Finish	Nerjavno jeklo + Belo steklo, Nerjavno jeklo + Črno steklo Stainless steel + white glass, stainless steel + black glass

OSVETLITEV LIGHTING

Tipi Type	LED 2 x 2,5 W
Intenzivna moč Intensity	141 LUX
Temperature Temperature	3500 K

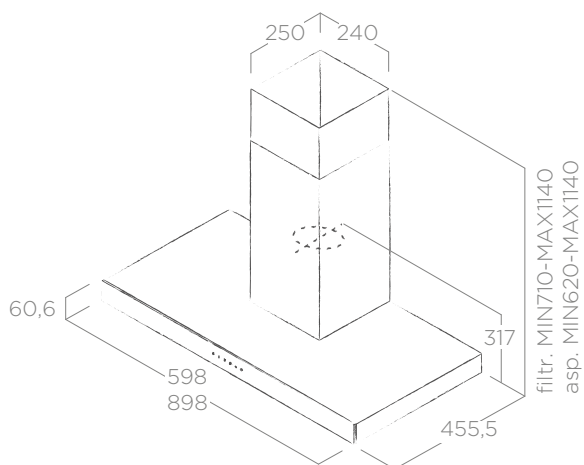

OBLIKA PERFORMANCE

Upravljanje Controls	3 Hitrosti + B na dotik 3S+B Touch Control
Pretok zraka Booster airflow	710 m ³ /h
Raven hrupa Noise level	69 db(A)
Popolna absorpcija Total absorption	265 W
Izhod Duct size	150 mm
Razred energetske učinkovitosti Energy class	B (A+/E)

Z aluminijastim mazalnim filtrom Grease aluminium Filter included

DODATKI ACCESSORIES

Ogleni filter Charcoal filter	CFC0141529
Filter s podaljšanim delovanjem Long life filter	CFC0141725

MODELI MODELS

JOY WHIX/A/60	PRF0104630A
JOY WHIX/A/90	PRF0104631A
JOY BLIX/A/60	PRF0104625A
JOY BLIX/A/90	PRF0104626A



FLAT GLASS

ELICA DESIGN CENTER



TEHNIČNI PODATKI TECHNICAL FEATURES

Velikost Size	60 - 90 cm
Izvedba Version	Odzračevalna Duct out
Videz Finish	Nerjavno jeklo + steklo Stainless steel + glass

OSVETLITEV LIGHTING

Tipi Type	LED 2 x 2,5 W
Intenzivna moč Intensity	141 LUX
Temperature Temperature	3500 K

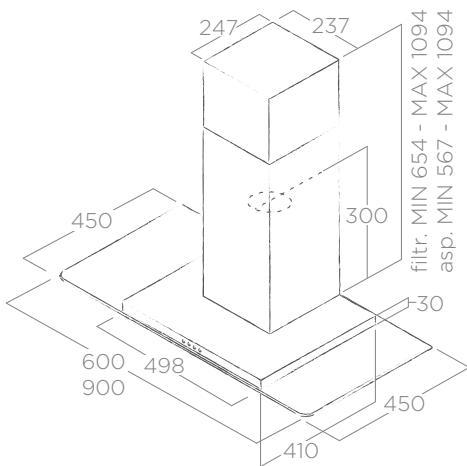

OBLIKA PERFORMANCE

Upravljanje Controls	3 Hitrosti meh. Gumbi 3S Mechanical Push Button
Maksimalni pretok zraka Max airflow	365 m ³ /h
Raven hrupa Noise level	62 db(A)
Popolna absorpcija Total absorption	140 W
Izhod Duct size	150 mm
Razred energetske učinkovitosti Energy class	D (A ⁺⁺ /E)

Z aluminijastim mazalnim filtrom Grease aluminium Filter included

DODATKI ACCESSORIES

Ogleni filter Charcoal Filter	CFC0141529
Filter s podaljšanim delovanjem Long Life Filter	CFC0141725

MODELI MODELS

FLAT GLASS IX/A/60	68516391A
FLAT GLASS IX/A/90	68516390A



CIRCUS

ELICA DESIGN CENTER



TEHNIČNI PODATKI TECHNICAL FEATURES

Velikost Size	60 - 90 cm
Izvedba Version	Odzračevalna Duct out
Videz Finish	Nerjavno jeklo + steklo Stainless steel + glass

OSVETLITEV LIGHTING

Tipi Type	LED 2 x 2,5 W
Intenzivna moč Intensity	141 LUX
Temperature Temperature	3500 K

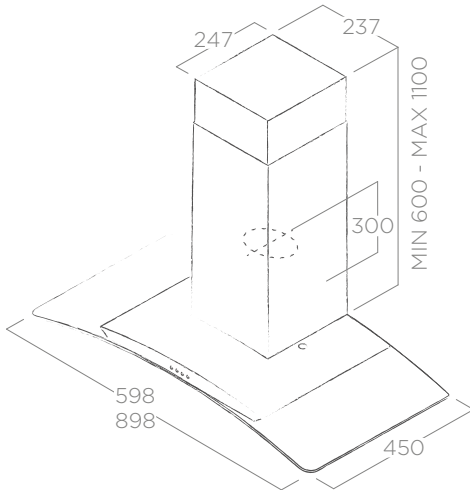

OBLIKA PERFORMANCE

Upravljanje Controls	3 Hitrosti meh. Gumbi 3s Mechanical Push Button
Maksimalni pretok zraka Max airflow	365 m ³ /h
Raven hrupa Noise level	62 db(A)
Popolna absorpcija Total absorption	140 W
Izhod Duct size	150 mm
Razred energetske učinkovitosti Energy class	D (A ⁺⁺ /E)

Z aluminijastim mazalnim filtrom Grease aluminium Filter included

DODATKI ACCESSORIES

Ogleni filter Charcoal Filter	CFC0141529
Filter s podaljšanim delovanjem Long Life Filter	CFC0141725

MODELI MODELS

CIRCUS IX/A/60	68116393A
CIRCUS IX/A/90	68116392A



TUBE PRO

ELICA DESIGN CENTER



TEHNIČNI PODATKI TECHNICAL FEATURES

Velikost Size	Ø 43 cm
Izvedba Version	Odzračevalna Duct-out
Videz Finish	Nerjavno jeklo, Črna, Bela Stainless steel, black, white

OSVETLITEV LIGHTING

Tipi Type	LED 2 x 3 W
Intenzivna moč Intensity	401 LUX
Temperature Temperature	3500 K

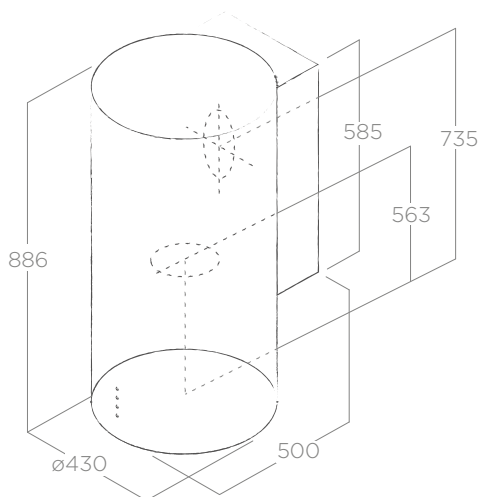

OBLIKA PERFORMANCE

Upravljanje Controls	3 Hitrosti meh. Gumbi 3s Mechanical Push Button
Maksimalni pretok zraka Max airflow	600 m ³ /h
Raven hrupa Noise level	68 db(A)
Popolna absorpcija Total absorption	256 W
Izhod Duct size	150 mm
Razred energetske učinkovitosti Energy class	C (A++/E)
Z aluminijastim mazalnim filtrom Grease aluminium Filter included	

DODATKI ACCESSORIES

Filter s podaljšanim delovanjem Long life filter	CFC0140423
--	------------

MODELI MODELS

TUBE PRO IX/A/43	PRF0080075A
TUBE PRO BL/A/43	PRF0090719A
TUBE PRO WH/A/43	PRF0090720A



STONE

ELICA DESIGN CENTER



TEHNIČNI PODATKI TECHNICAL FEATURES

Velikost Size	Ø33 cm
Izvedba Version	Odzračevalna Duct out
Videz Finish	Nerjavno jeklo, Bela Stainless steel, white

OSVETLITEV LIGHTING

Tipi Type	LED 2 x 2,5 W
Intenzivna moč Intensity	141 LUX
Temperature Temperature	2700 K

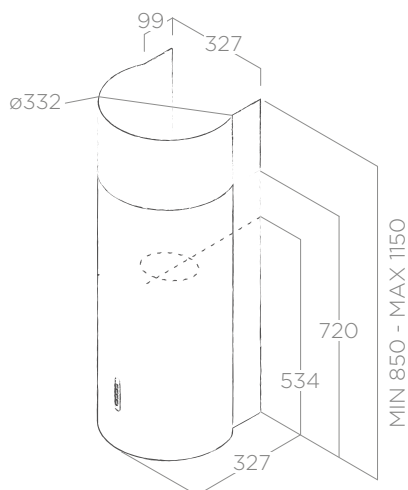

OBLIKA PERFORMANCE

Upravljanje Controls	3 Hitrosti soft light gumbi 3S Soft light Push Button
Maksimalni pretok zraka max airflow	625 m ³ /h
Raven hrupa Noise level	70 db(A)
Popolna absorpcija Total absorption	180 W
Izhod Duct size	150 mm
Razred energetske učinkovitosti Energy class	C (A ⁺⁺ /E)

Z aluminijastim mazalnim filtrom Grease aluminium Filter included

DODATKI ACCESSORIES

Ogleni filter Charcoal filter	CFC0141529
Filter s podaljšanim delovanjem Long life filter	CFC0141725

MODELI MODELS

STONE IX/A/33	61412862B
STONE WH/A/33	PRF0007123A





CM 50



CM 65



ENERGY CLASS

TEHNIČNI PODATKI TECHNICAL FEATURES

Velikost Size	60 - 90 cm
Izvedba Version	Odzračevalna Duct out
Videz Finish	Nerjavno jeklo, Črna, Bela Stainless steel, black, white

OSVETLITEV LIGHTING

Tipi Type	LED 2 x 3 W
Intenzivna moč Intensity	121 LUX
Temperature Temperature	2700 K

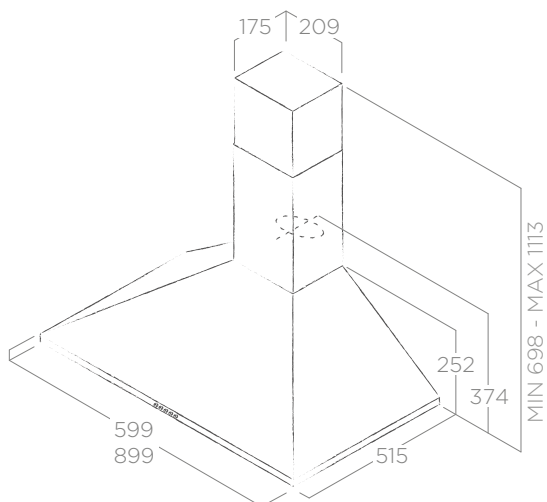

OBLIKA PERFORMANCE

Upravljanje Controls	3 Hitrosti meh. Gumbi 3S Mechanical Push Button
Maksimalni pretok zraka max airflow	430 m ³ /h
Raven hrupa Noise level	62 db(A)
Popolna absorpcija Total absorption	186 W
Izhod Duct size	120 mm
Razred energetske učinkovitosti Energy class	D (A++/E)

Z aluminijastim mazalnim filtrom Grease aluminium Filter included

DODATKI ACCESSORIES

Ogleni filter Charcoal filter	CFC0140124
Filtro grassi professionale Professional grease filter	KIT01036
Est. camino Inox Ext. Chimney Inox (+200mm)	KIT00778A
Est. camino Inox Ext. Chimney Inox (+420mm)	KIT00779A
Est. camino Nero Ext. Chimney Black (+420mm)	KIT0110060
Est. camino Bianco Ext. Chimney White (+420mm)	KIT0110061

MODELI MODELS

TAMAYA PB IX/A/60	PRF0009706C
TAMAYA PB IX/A/90	PRF0009794C
TAMAYA PB BL/A/60	PRF0009834C
TAMAYA PB BL/A/90	PRF0009854C
TAMAYA PB WH/A/60	PRF0009861C
TAMAYA PB WH/A/90	PRF0009880C



TAMAYA RAIL

ELICA DESIGN CENTER



TEHNIČNI PODATKI TECHNICAL FEATURES

Velikost Size	60 - 90 cm
Izvedba Version	Odzračevalna Duct out
Videz Finish	Antracite, avorio + reggimestolo bronzato Anthracite, ivory + bronze ladle holder

OSVETLITEV LIGHTING

Tipi Type	LED 2 x 3 W
Intenzivna moč Intensity	121 LUX
Temperature Temperature	2700 K

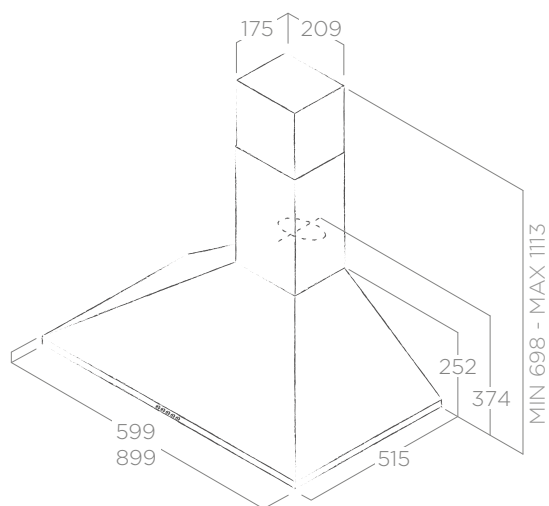

OBLIKA PERFORMANCE

Upravljanje Controls	3 Hitrosti meh. Gumbi 3S Mechanical Push Button
Maksimalni pretok zraka max airflow	430 m ³ /h
Raven hrupa Noise level	62 db(A)
Popolna absorpcija Total absorption	146 W
Izhod Duct size	150 mm
Razred energetske učinkovitosti Energy class	D (A++/E)

Z aluminijastim mazalnim filtrom Grease aluminium Filter included

DODATKI ACCESSORIES

Ogleni filter Charcoal filter	CFC0140124
Filtro grassi professionale Professional grease filter	KIT01036
Podaljšek za dimnik antracitno siva Ext. Chimney Anthracite(+420mm)	KIT0110062
Podaljšek za dimnik bela slonovina Ext. Chimney Ivory (+420mm)	KIT0110063

MODELI MODELS

TAMAYA RAIL ANBR/A/60	PRF0057590B
TAMAYA RAIL ANBR/A/90	PRF0057591B
TAMAYA RAIL CRBR/A/60	PRF0057592B
TAMAYA RAIL CRBR/A/90	PRF0057593B





TEHNIČNI PODATKI TECHNICAL FEATURES

Velikost Size	60 - 90 cm
Izvedba Version	Odzračevalna Duct out
Videz Finish	Nerjavno jeklo, Bela Stainless steel, white

OSVETLITEV LIGHTING

Tipi Type	LED 2 x 3 W
Intenzivna moč Intensity	97 LUX
Temperature Temperature	3700 K

OBLIKA PERFORMANCE

Upravljanje Controls	3 Hitrosti meh. Gumbi 3S Mechanical Push Button
Maksimalni pretok zraka max airflow	392 m ³ /h
Raven hrupa Noise level	68 db(A)
Popolna absorpcija Total absorption	96 W
Izhod Duct size	150 mm
Razred energetske učinkovitosti Energy class	D (A ⁺⁺ /E)

Z aluminijastim mazalnim filtrom Grease aluminium Filter included

DODATKI ACCESSORIES

Ogleni filter Charcoal Filter	CFC0141497
-------------------------------	------------

MODELI MODELS

MISSY LX IX/A/60	PRF0057572B
MISSY LX IX/A/90	PRF0057573B
MISSY LX WH/A/60	PRF0057574B

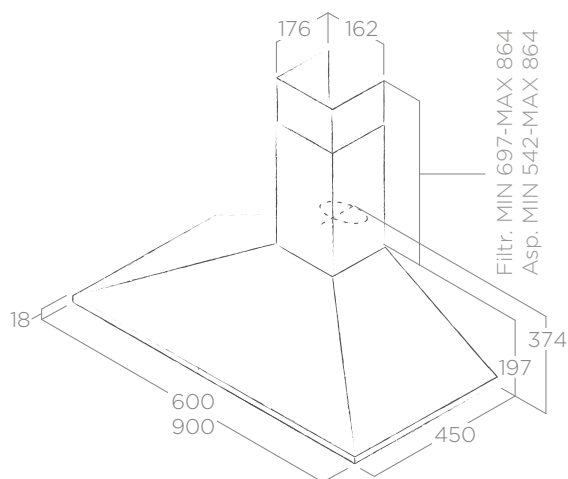



CM 50



CM 65



ENERGY CLASS

TEHNIČNI PODATKI TECHNICAL FEATURES

Velikost Size	60 - 90 cm
Izvedba Version	Odzračevalna Duct out
Videz Finish	Antracitno siva, slonovina Anthracite, ivory

OSVETLITEV LIGHTING

Tipi Type	LED 2 x 3 W
Intenzivna moč Intensity	102 LUX
Temperature Temperature	2700 K

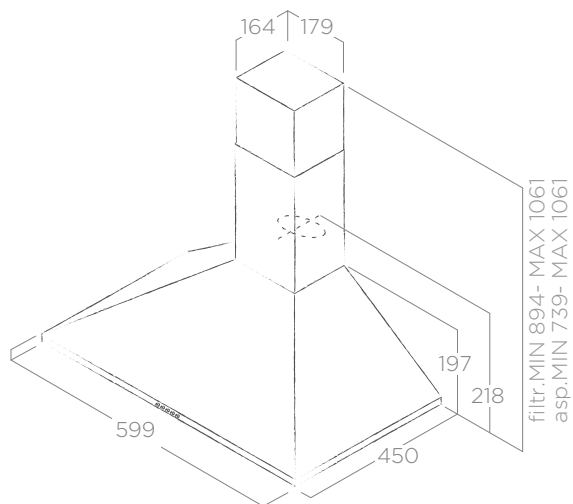

OBLIKA PERFORMANCE

Upravljanje Controls	3 Hitrosti meh. Gumbi 3S Mechanical Push Button
Maksimalni pretok zraka max airflow	392 m ³ /h
Raven hrupa Noise level	68 db(A)
Popolna absorpcija Total absorption	96 W
Izhod Duct size	150 mm
Razred energetske učinkovitosti Energy class	D (A++/E)
Z aluminijastim mazalnim filtrom Grease aluminium Filter included	

DODATKI ACCESSORIES

Ogleni filter Charcoal filter	CFC0141497
-------------------------------	------------

MODELI MODELS

BERLIN AN/A/60	PRF0123178B
BERLIN CR/A/60	PRF0123188B



TEHNIČNI PODATKI TECHNICAL FEATURES

Velikost Size	100 cm
Izvedba Version	Obtočna izvedba Recycling
Videz Finish	Nerjavno jeklo, Črna Stainless steel, black

OSVETLITEV LIGHTING

Tipi Type	LED 4 x 2,5 W
Intenzivna moč Intensity	141 LUX
Temperature Temperature	3500 K

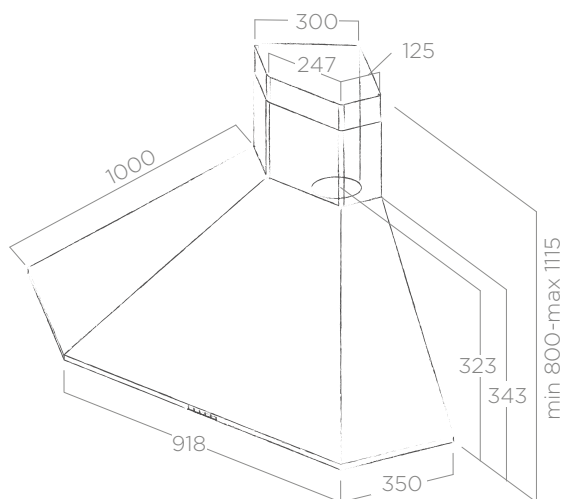

OBLIKA PERFORMANCE

Upravljanje Controls	3 Hitrosti + B na dotik 3S+B Touch Control
Pretok zraka Booster airflow	625 m ³ /h
Raven hrupa Noise level	60 db(A)
Popolna absorpcija Total absorption	210 W
Izhod Duct size	150 mm
Razred energetske učinkovitosti Energy class	A (A++/E)

Z aluminijastim mazalnim filtrom Grease aluminium Filter included
Ogleni filter vključen Charcoal Filter included

DODATKI ACCESSORIES

Ogleni filter Charcoal Filter	CFC0140343
-------------------------------	------------

MODELI MODELS

ACUTA IX/F/100	PRF0121267A
ACUTA BL/F/100	PRF0127462A



CORALINE

ELICA DESIGN CENTER



TEHNIČNI PODATKI TECHNICAL FEATURES

Velikost Size	60 - 90 cm
Izvedba Version	Odzračevalna Duct out
Videz Finish	Bela White
Cornice Frame	Tuliper grezzo Unfinished tulipwood

OSVETLITEV LIGHTING

Tipi Type	LED 2 x 3 W
Intenzivna moč Intensity	73 LUX
Temperature Temperature	2700 K

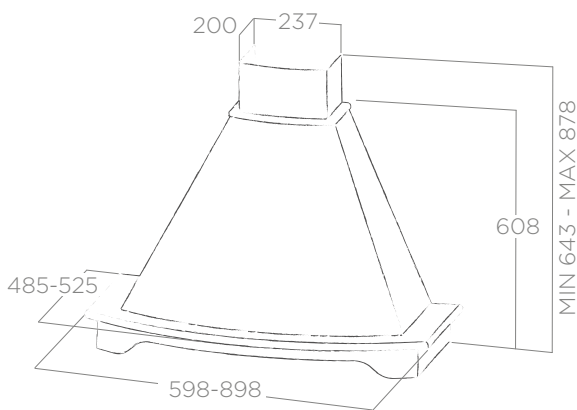

OBLIKA PERFORMANCE

Upravljanje Controls	3 Hit. drsno stikalo 3S Slider
Maksimalni pretok zraka max airflow	435 m ³ /h
Raven hrupa Noise level	65 db(A)
Popolna absorpcija Total absorption	146 W
Izhod Duct size	120 mm
Razred energetske učinkovitosti Energy class	D (A ⁺⁺ /E)

Z aluminijastim mazalnim filtrom Grease aluminium Filter included

DODATKI ACCESSORIES

Ogleni filter Charcoal filter	CFC0140124
-------------------------------	------------

MODELI MODELS

CORALINE WH/A/60 T.GREZZO	PRF0041810B
CORALINE WH/A/90 T.GREZZO	PRF0041832B



EMERALD

ELICA DESIGN CENTER



CM 50



CM 65



ENERGY CLASS

TEHNIČNI PODATKI TECHNICAL FEATURES

Velikost Size	60 - 90 cm
Izvedba Version	Odzračevalna Duct out
Videz Finish	Bela White
Cornice Frame	Tuliper grezzo Unfinished tulipwood

OSVETLITEV LIGHTING

Tipi Type	LED 2 x 3 W
Intenzivna moč Intensity	73 LUX
Temperature Temperature	2700 K

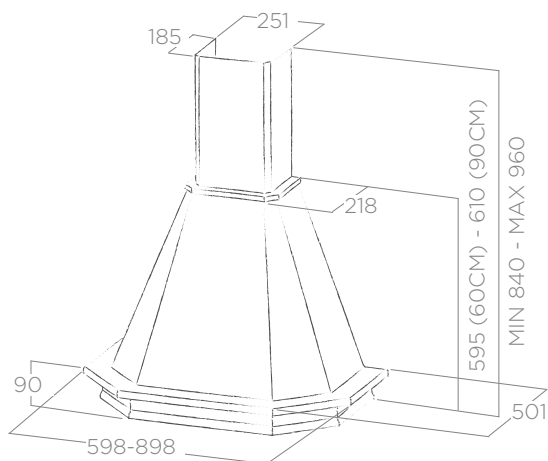

OBLIKA PERFORMANCE

Upravljanje Controls	3 Hit. drsno stikalo 3S Slider
Maksimalni pretok zraka max airflow	435 m ³ /h
Raven hrupa Noise level	65 db(A)
Popolna absorpcija Total absorption	146 W
Izhod Duct size	120 mm
Razred energetske učinkovitosti Energy class	D (A ⁺⁺ /E)

Z aluminijastim mazalnim filtrom Grease aluminium Filter included

DODATKI ACCESSORIES

Ogleni filter Charcoal filter	CFC0140124
-------------------------------	------------

MODELI MODELS

EMERALD WH/A/60 T.GREZZO	PRF0041870B
EMERALD WH/A/90 T.GREZZO	PRF0041890B





Ekskluzivni zastopnik za Slovenijo:

PMF d.o.o.
Letališka cesta 3c
1000 Ljubljana

Tel: 01 513 51 64
Fax: 01 513 52 08
E-pošta: elica@pmf.si
www.pmf.si

