



SWITCH YOUR KITCHEN
UPSIDE DOWN

PMF

 elica
aria nuova



SUSPENDED



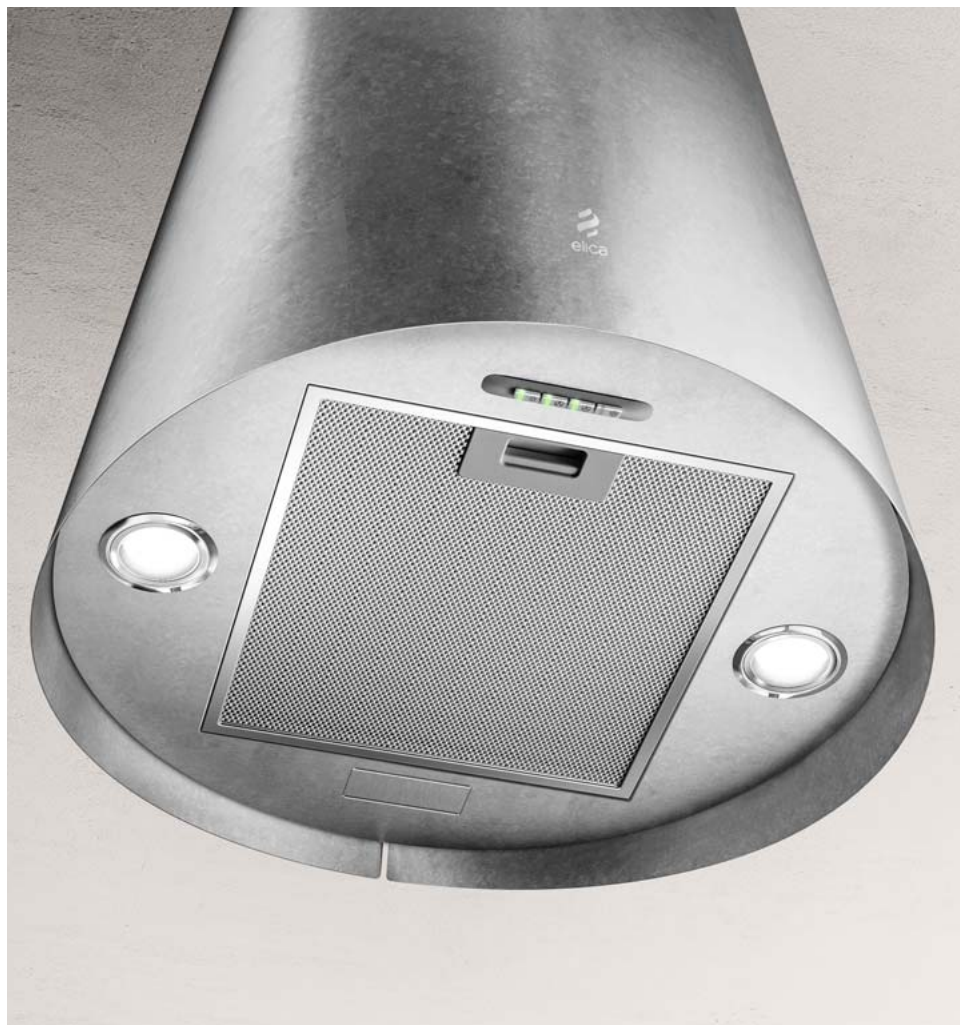

JUNO URBAN

ELICA DESIGN CENTER

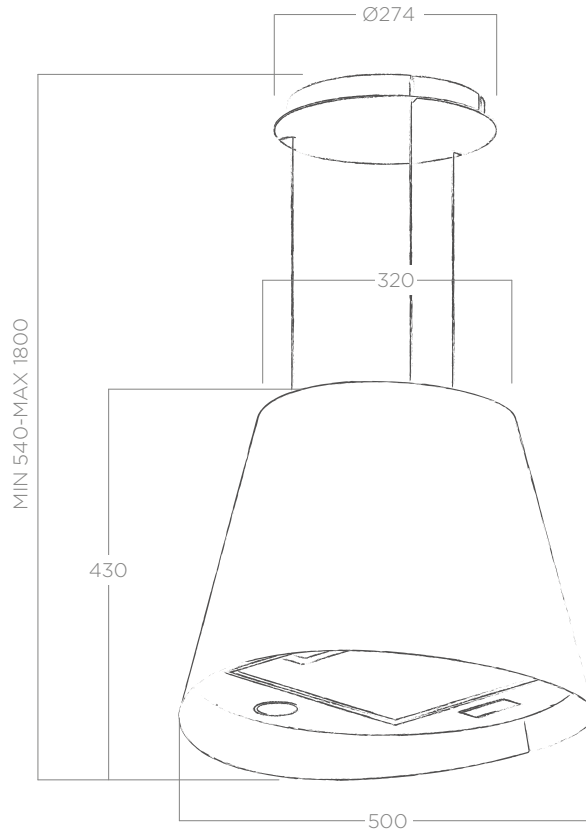

LONG LIFE
FILTER



ENERGY
CLASS



CM 50



CM 65

TEHNIČNI PODATKI TECHNICAL FEATURES

Velikost Size	Ø 50 cm
Izvedba Version	Obtočna izvedba Recycling
Videz Finish	Železni izgled, Pocinkan izgled Cast iron effect, Zinc coating effect

OSVETLITEV LIGHTING

Tipi Type	LED 2 X 2,5 W
Intenzivna moč Intensity	140 LUX
Temperature Temperature	3500 K

OBLIKA PERFORMANCE

Upravljanje Controls	3 Hitrosti soft light gumbi 3S Soft Light Push Button
Maksimalni pretok zraka Max airflow	600 m ³ /h
Raven hrupa Noise level	67 db(A)
Popolna absorbcija Total absorption	250 W
Izhod Duct size	150 mm
Razred energetske učinkovitosti Energy class	A (A**/E)

DODATKI ACCESSORIES

Filter s podaljšanim delovanjem Long Life Filter	CFC0140088
Komplet za inštalacijo na steno wall mounted kit	KIT02263
Podaljšek (2,5m) Extension cable kit (2,5m)	KIT01889
Podaljšek (5m) Extension cable kit (5m)	KIT01921

MODELI MODELS

Z aluminijastim mazalnim filtrom Grease aluminium filter included
Z ogljenim filtrom s podaljšanim delovanjem Long Life filter included

JUNO URBAN CAST IRON/F/50
JUNO URBAN ZINC/F/50

PRF0147728
PRF0147730

JUNO

ELICA DESIGN CENTER



TEHNIČNI PODATKI TECHNICAL FEATURES

Velikost Size	Ø 50 cm
Izvedba Version	Obtočna izvedba Recycling
Videz Finish	Nerjavno jeklo, bianco, Črna Stainless steel, white, black

OSVETLITEV LIGHTING

Tipi Type	LED 2 X 2,5 W
Intenzivna moč Intensity	140 LUX
Temperature Temperature	3500 K

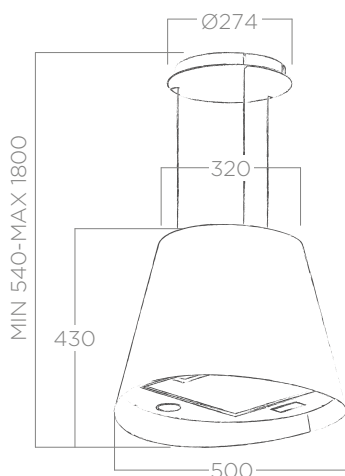

OBLIKA PERFORMANCE

Upravljanje Controls	3 Hitrosti soft light gumbi 3S Soft Light Push Button
Maksimalni pretok zraka Max airflow	600 m ³ /h
Raven hrupa Noise level	67 db(A)
Popolna absorpcija Total absorption	250 W
Izhod Duct size	150 mm
Razred energetske učinkovitosti Energy class	A (A ⁺⁺ /E)

Z aluminijastim mazalnim filtrom Grease aluminium filter included
Z ogljenim filtrom s podaljšanim delovanjem Long Life filter included

DODATKI ACCESSORIES

Filter s podaljšanim delovanjem Long Life Filter	CFC0140088
Komplet za inštalacijo na steno wall mounted kit	KIT02263
Podaljšek (2,5m) Extension cable kit (2,5m)	KIT01889
Podaljšek (5m) Extension cable kit (5m)	KIT01921

MODELI MODELS

JUNO IX/F/50	PRF0089651B
JUNO WH/F/50	PRF0071972B
JUNO BL/F/50	PRF0071970B



NAKED URBAN

ELICA DESIGN CENTER



TEHNIČNI PODATKI TECHNICAL FEATURES

Velikost Size	Ø 25 cm
Izvedba Version	Obtočna izvedba Recycling
Videz Finish	Železni izgled, Pocinkan izgled Cast iron effect, Zinc coating effect

OSVETLITEV LIGHTING

Tipi Type	LED 1 X 5 W
Intenzivna moč Intensity	145 LUX
Temperature Temperature	4000 K

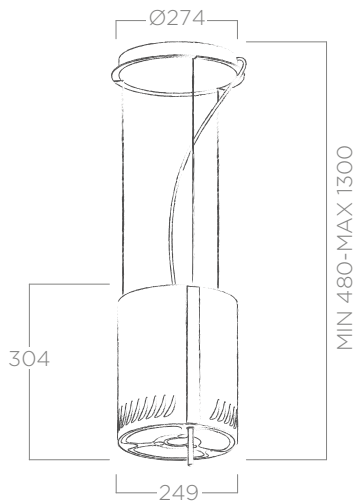

OBLIKA PERFORMANCE

Upravljanje Controls	3 Hitrosti + B Magic Wand 3S+B Magic Wand
Pretok zraka Booster airflow	515 m³/h
Raven hrupa Noise level	66 db(A)
Popolna absorpcija Total absorption	225 W
Izhod Duct size	150 mm
Razred energetske učinkovitosti Energy class	B (A++/E)

Z aluminijastim mazalnim filtrom Grease aluminium filter included
Z ogljenim filtrom s podaljšanim delovanjem Long Life filter included

DODATKI ACCESSORIES

Filter s podaljšanim delovanjem Long Life Filter	CFC0140384
Podaljšek (2,5m) Extension cable kit (2,5m)	KIT01889
Podaljšek (5m) Extension cable kit (5m)	KIT01921
Bel daljinski upravljalnik White remote control	KIT0121468
Črni daljinski upravljalnik Black remote control	KIT0121469

MODELI MODELS

NAKED URBAN CAST IRON/F/25	PRF0147733
NAKED URBAN ZINC/F/25	PRF0147734



Pocinkan izgled
Zinc coating effect



Železni izgled
Cast iron effect

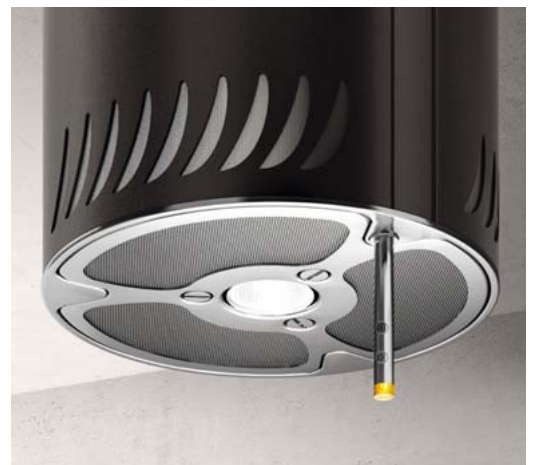



Ekskluzivni zastopnik za Slovenijo:

PMF d.o.o.
Letališka cesta 3c
1000 Ljubljana

Tel: 01 513 51 64
Fax: 01 513 52 08
E-pošta: elica@pmf.si
www.pmf.si

