



SWITCH YOUR KITCHEN
UPSIDE DOWN

PMF

 elica
aria nuova

ISLAND







HAIKU ISLAND BLACK



HAIKU ISLAND INOX



HAIKU ISLAND WHITE



HAIKU ISLAND CONCRETE

HAIKU ISLAND

DESIGN FABRIZIO CRISÀ

AWARDS



SPECIAL MATERIAL



ENERGY CLASS

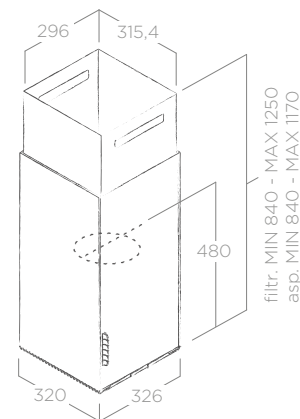
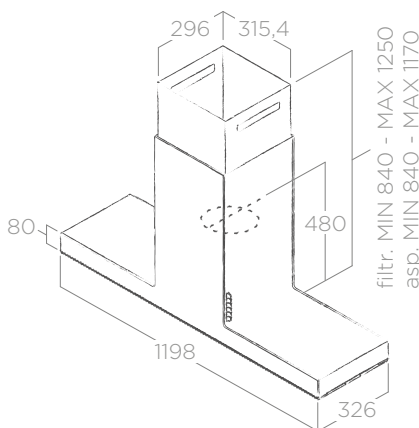
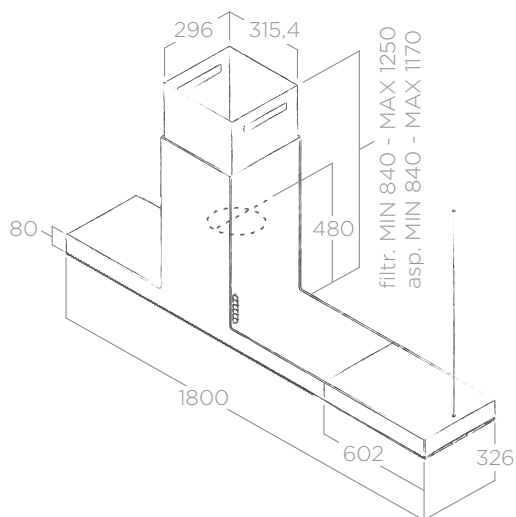

LONG LIFE FILTER



CM 60



CM 65

TEHNIČNI PODATKI TECHNICAL FEATURES

Velikost Size	32x32 - 32x120 - 32x180 cm
Izvedba Version	Odzračevalna Duct-out
Videz Finish	Črno steklo, Bel Krion, Porcelanska lončevina s cementnim učinkom, Nerjavno jeklo Black glass, white Krion, cement effect stonewear, stainless steel

OSVETLITEV LIGHTING

Tipi Type	Stripe Led 1x7 W
Intenzivna moč Intensity	281 LUX
Temperature Temperature	3500 K

OBLIKA PERFORMANCE

Upravljanje Controls	3 Hitrosti + 2B na dotik 3S+2B Touch Control
Pretok zraka Booster airflow	720 m ³ /h
Raven hrupa Noise level	53 db(A)
Popolna absorpcija Total absorption	260 W
Izhod Duct size	150 mm
Razred energetske učinkovitosti Energy class	A (A++/E)
Z aluminijastim mazalnim filtrom	Grease aluminium filter included

DODATKI ACCESSORIES

Ogleni filter Charcoal Filter	CFC0141529
Filter s podaljšanim delovanjem Long Life Filter	CFC0141725

MODELJI MODELS

HAIKU ISLAND BL/A/32	PRF0146285
HAIKU ISLAND WH/A/32	PRF0146289
HAIKU ISLAND IX/A/32	PRF0146277
HAIKU ISLAND CONCRETE/A/32	PRF0146281
HAIKU ISLAND BL/A/120	PRF0146286
HAIKU ISLAND WH/A/120	PRF0146290
HAIKU ISLAND IX/A/120	PRF0146279
HAIKU ISLAND CONCRETE/A/120	PRF0146282
HAIKU ISLAND BL/A/180	PRF0146287
HAIKU ISLAND WH/A/180	PRF0146291
HAIKU ISLAND IX/A/180	PRF0146280
HAIKU ISLAND CONCRETE/A/180	PRF0146284

BIO ISLAND

DESIGN FABRIZIO CRISÀ



TEHNIČNI PODATKI TECHNICAL FEATURES

Velikost Size	120x53 cm
Izvedba Version	Odzračevalna Duct-out
Videz Finish	Naravni hrast + Bela, z učinkom mehkega dotika Natural oak + white soft touch effect

OSVETLITEV LIGHTING

Tipi Type	Stripe Led 2x7 W
Intenzivna moč Intensity	141 LUX
Temperature Temperature	2700-6000 K

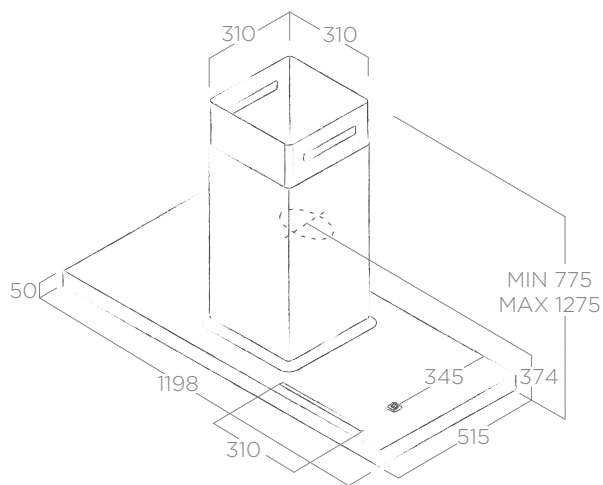

OBLIKA PERFORMANCE

Upravljanje Controls	3 Hitrosti + 2B na dotik 3S+2B Touch Control
Pretok zraka Booster airflow	757 m ³ /h
Raven hrupa Noise level	60 db(A)
Popolna absorpcija Total absorption	324 W
Izhod Duct size	150 mm
Razred energetske učinkovitosti Energy class	A+ (A++/E)
Z aluminijastim mazalnim filtrom Grease aluminium filter included	

DODATKI ACCESSORIES

Plošča s 60cm Shelf kit 60cm	KIT0120947
Polica kabel kit 1,7mt Cables kit 1,7mt	KIT0120948
Bel daljinski upravljalnik White remote control	KIT0121468
Črni daljinski upravljalnik Black remote control	KIT0121469
Revolucijski filter Revolution filter	CFC0140091



Nosilec in vtičnica USB za polnjenje tablice.
Support and USB outlet to charge a table.



Daljinski upravljalnik. Glejte stran 151 za razpoložljivi model.
Kit remote control optional. See page 151 for available design.



Komplet polica na str.154
Shelf kit on page 154

MODELI MODELS

BIO ISLAND WH/A/120X53 ROVERE	PRF0148081
-------------------------------	------------

AWARDS



reddot design award
winner 2017



THIN ISLAND

DESIGN FABRIZIO CRISÀ



SMART
INSTALLATION



LONG LIFE
FILTER



CM 60



CM 65



ENERGY
CLASS
A

TEHNIČNI PODATKI TECHNICAL FEATURES

Velikost Size	120x57 cm
Izvedba Version	Odzračevalna Duct-out
Videz Finish	Nerjavno jeklo Stainless steel

OSVETLITEV LIGHTING

Tipi Type	Stripe Led 1x7 W
Intenzivna moč Intensity	281 LUX
Temperature Temperature	3500 K

OBLIKA PERFORMANCE

Upravljanje Controls	3 Hitrosti + 2B na dotik 3S+2B Touch Control
Pretok zraka Booster airflow	710 m ³ /h
Raven hrupa Noise level	54 db(A)
Popolna absorpcija Total absorption	317 W
Izhod Duct size	150 mm
Razred energetske učinkovitosti Energy class	A (A++/E)
Z aluminijastim mazalnim filtrom Grease aluminium filter included	

DODATKI ACCESSORIES

Ogleni filter Charcoal Filter	CFC0141529
Filter s podaljšanim delovanjem Long Life Filter	CFC0141725

MODELI MODELS

THIN ISLAND IX/A/120	PRF0144973
----------------------	------------

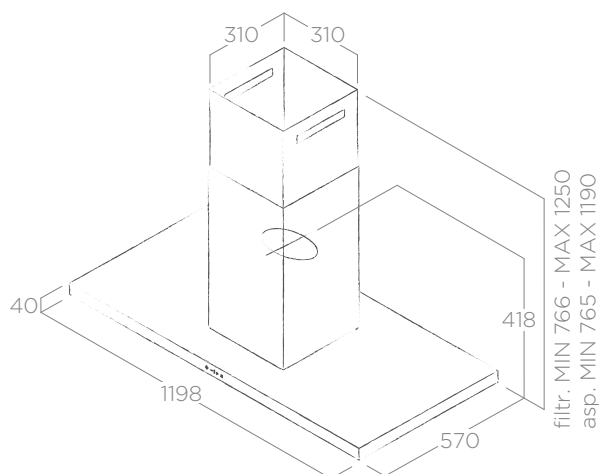

METEORITE ISLAND

DESIGN FABRIZIO CRISÀ



REVOLUTION
FILTER



TUNE WHITE



CM 50



CM 65



ENERGY
CLASS

TEHNIČNI PODATKI TECHNICAL FEATURES

Velikost Size	120x60 cm
Izvedba Version	Odzračevalna Duct-out
Videz Finish	Nerjavno jeklo + črno steklo Stainless steel + black glass

OSVETLITEV LIGHTING

Tipi Type	Stripe Led 2x7 W
Intenzivna moč Intensity	141 LUX
Temperature Temperature	2700-6000 K

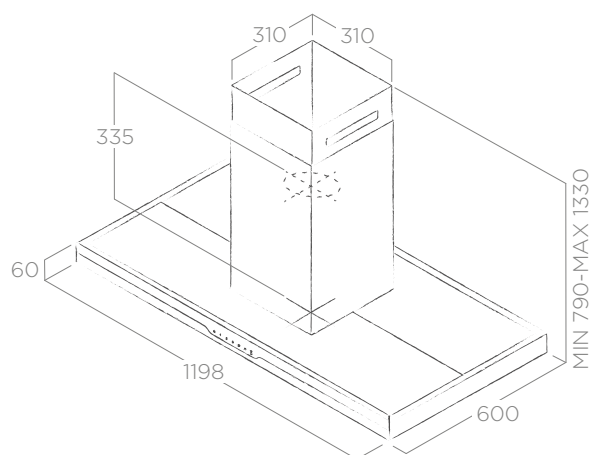

OBLIKA PERFORMANCE

Upravljanje Controls	3 Hitrosti + 2B na dotik 3S+2B Touch Control
Pretok zraka Booster airflow	757 m ³ /h
Raven hrupa Noise level	59 db(A)
Popolna absorpcija Total absorption	324 W
Izhod Duct size	150 mm
Razred energetske učinkovitosti Energy class	A (A++/E)
Z aluminijastim mazalnim filtrom Grease aluminium filter included	

DODATKI ACCESSORIES

Bel daljinski upravljalnik White remote control	KIT0121468
Črni daljinski upravljalnik Black remote control	KIT0121469
Revolucijski filter Revolution filter	CFC0140091



Daljinski upravljalnik. Glejte stran 151 za razpoložljivi model.
Kit remote control optional. See page 151 for available design.

MODELI MODELS

METEORITE ISLAND IX/A/120x60	PRF0148122
------------------------------	------------



GALAXY ISLAND

ELICA DESIGN CENTER



TEHNIČNI PODATKI TECHNICAL FEATURES

Velikost Size	90x45 cm
Izvedba Version	Odzračevalna Duct-out
Videz Finish	Nerjavno jeklo + Belo steklo/Črno steklo Stainless steel + white glass/black glass

OSVETLITEV LIGHTING

Tipi Type	Led 4x2,5 W
Intenzivna moč Intensity	290 LUX
Temperature Temperature	3500 K

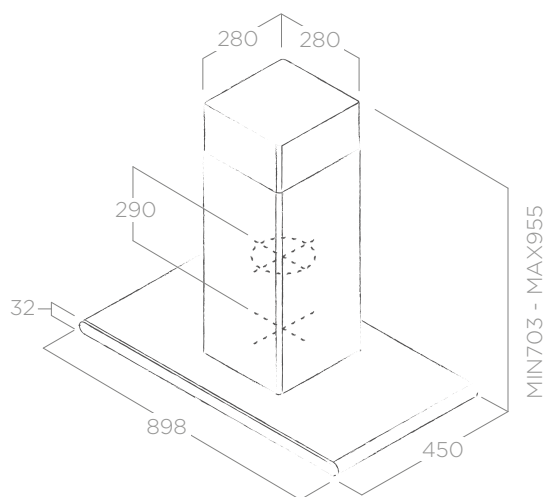

OBLIKA PERFORMANCE

Upravljanje Controls	3 Hitrosti + B na dotik 3S+B Touch Control
Pretok zraka Booster airflow	645 m ³ /h
Raven hrupa Noise level	69 db(A)
Popolna absorpcija Total absorption	270 W
Izhod Duct size	150 mm
Razred energetske učinkovitosti Energy class	C (A ⁺⁺ /E)

Z aluminijastim mazalnim filtrom Grease aluminium Filter included

DODATKI ACCESSORIES

Ogleni filter Charcoal Filter	CFC0141529
Filter s podaljšanim delovanjem Long Life Filter	CFC0141725

MODELI MODELS

GALAXY ISLAND BLIX/A/90x45	PRF0017852B
GALAXY ISLAND WHIX/A/90x45	PRF0019192B





MOON ISLAND

ELICA DESIGN CENTER



LONG LIFE
FILTER



ENERGY
CLASS

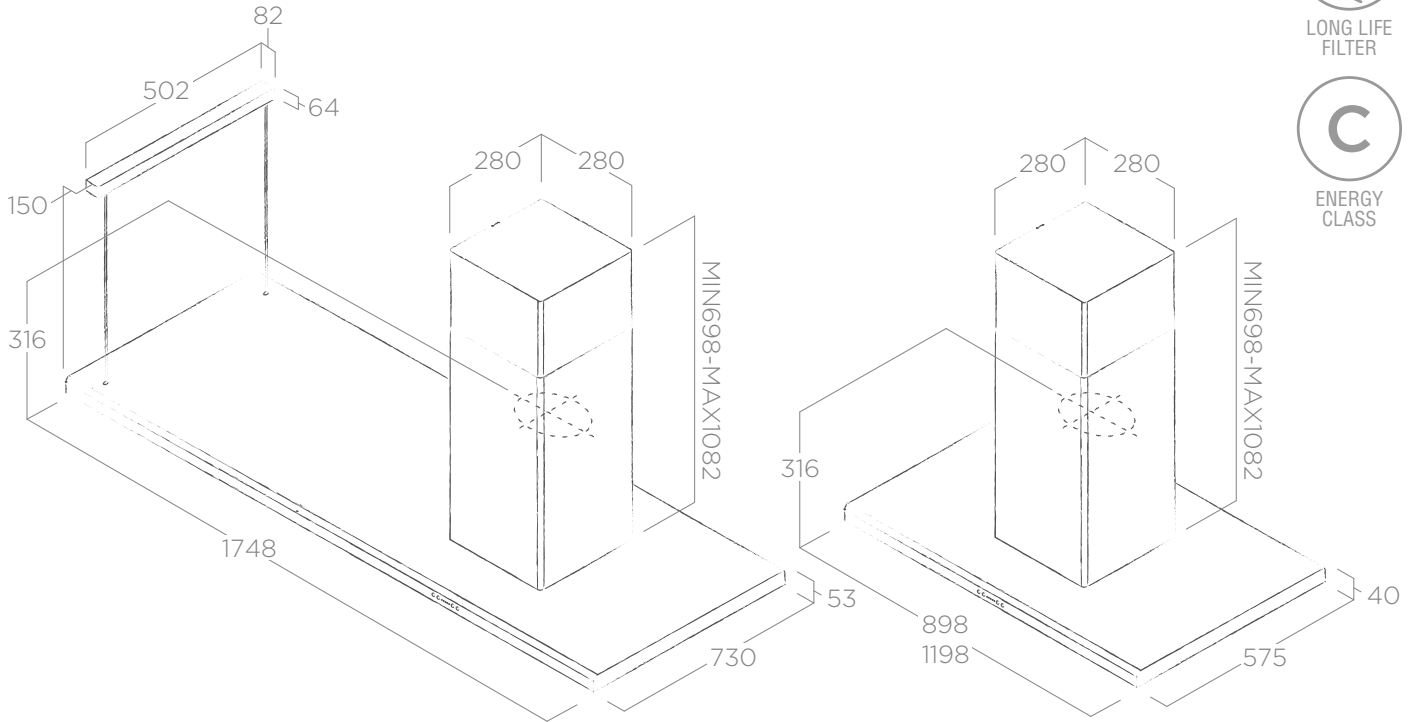

CM 50



CM 65

TEHNIČNI PODATKI TECHNICAL FEATURES

Velikost Size	90x57 - 120x57 - 175x73 cm
Izvedba Version	Odzračevalna Duct-out - Obtočna izvedba Filtering (180cm)
Videz Finish	Nerjavno jeklo Stainless steel

OSVETLITEV LIGHTING

Tipi Type	Neon 2x21W (90cm) 2X28W (120cm) 4x21W (180cm)
Intenzivna moč Intensity	210 (90cm) - 280 (120cm) - 252 (180cm) LUX
Temperature Temperature	6500 K

OBLIKA PERFORMANCE

Upravljanje Controls	3 Hitrosti + B na dotik 3S+B Touch Control
Pretok zraka Booster airflow	690 m ³ /h
Raven hrupa Noise level	68 db(A)
Popolna absorpcija Total absorption	302 (90cm) - 316 (120cm) - 344 (180cm) W
Izhod Duct size	150 mm
Razred energetske učinkovitosti Energy class	C (A+/E)
Z aluminijastim mazalnim filtrom Grease aluminium Filter included	
Ogleni filter vključen Charcoal filter included (*)	

DODATKI ACCESSORIES

Ogleni filter Charcoal Filter	CFC0141529
Filter s podaljšanim delovanjem Long Life Filter	CFC0141725

MODELI MODELS

MOON IS IX/A/60X90	PRF0093507A
MOON IS IX/A/60X120	PRF0093541A
MOON ISLAND IX/F/180 (*)	PRF0079552A



Ekskluzivni zastopnik za Slovenijo:

PMF d.o.o.
Letališka cesta 3c
1000 Ljubljana

Tel: 01 513 51 64
Fax: 01 513 52 08
E-pošta: elica@pmf.si
www.pmf.si

